

# Technical Specification/ Product Datasheet



## KK-FRP AND KONCRETE PRODUCTS PVT LTD

1114 Hubtown Solaris  
Prof N.S Phadke Road, Andheri (E)  
Mumbai-400 069  
INDIA  
Ph: +91 22 66913250 ,  
Mob: +91 9822036550 / 9850089903 ,  
email: [info@kkfrp.com](mailto:info@kkfrp.com) / [kkmgnsk@gmail.com](mailto:kkmgnsk@gmail.com)  
Web: [www.kkfrp.com](http://www.kkfrp.com)



Specific Product Code/s:	MCEHD09
Product Group:	KK-FRP FIBREGLASS COMPOSITE MANHOLE COVER & FRAME
Sub-Category:	Extra Heavy Duty EHD 40 T Cap. As per BSEN124:2015
Material Composition :	Unsaturated Polyester Resin UV Resistant ISO Grade, Emulsion Fibreglass Matt E Class, Accelerators, UV Resistant Pigment, Polymer Concrete in Quartz as Core,
Basic Dimensions (mm):	Clear Opening 450 x 600 mm Cover Size: 530 x 680 mm Cover Height: 50 mm Frame Size: 630 x 780 mm Frame Height: 80 mm
Weight (kgs):	Approx. 56 kg
Load Rating Classification:	D400 (40T)
Features:	<ul style="list-style-type: none"><li>➤ FRP Manhole Cover &amp; Frame D400 as per BSEN124.</li><li>➤ Heavy duty design to cope with the demands of heavily traffic in Main Roads , carriageways , Parkings etc.</li><li>➤ Key Holes 2nos with <b>(SS Key optional)</b> &amp; Lifting device provided .</li><li>➤ Choice of Colour Available.</li><li>➤ Anti skid surface.</li><li>➤ Waterproof, Weatherproof, Burglar proof , Non corrossive, High Strenght to Wt ratio, Easy of handing as Light wt , Heat Resistant, Shockproof .</li><li>➤ Provision for Logo of Buyer.</li><li>➤ Additional Provision of Gasket (O-Ring) 6 mm Dia &amp; SS Nut Bolts with Washer to make Water Tight <b>(Optional)</b> .</li></ul>

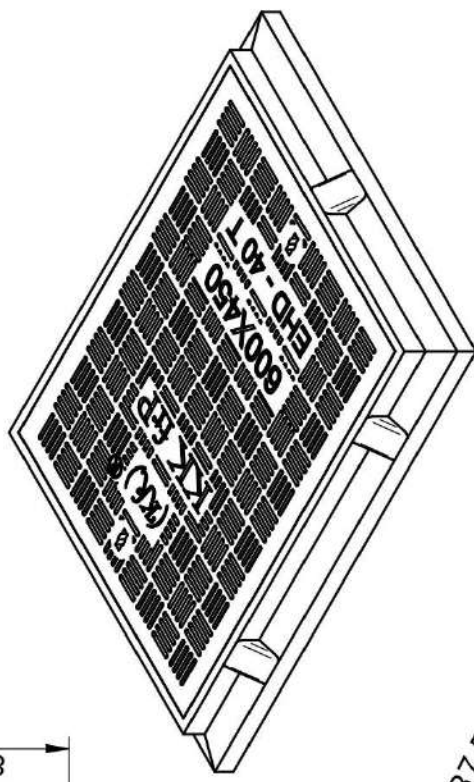
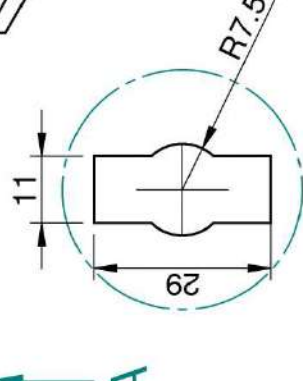
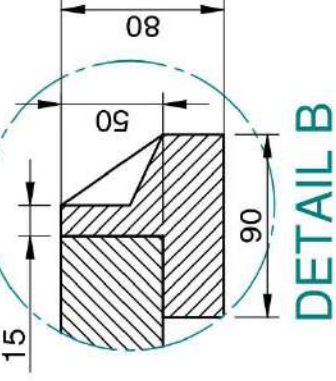
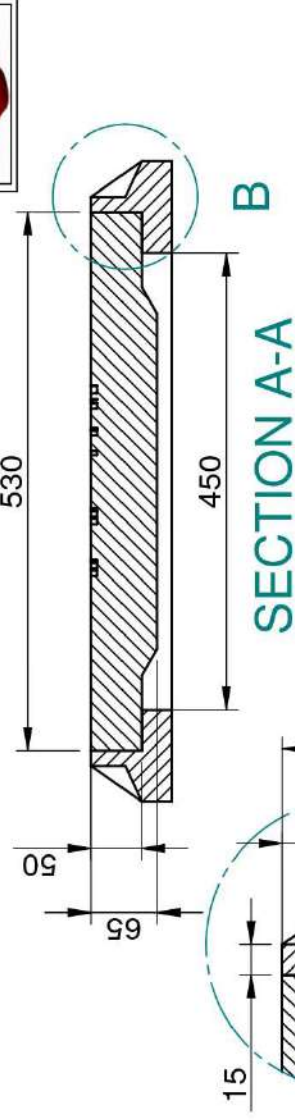
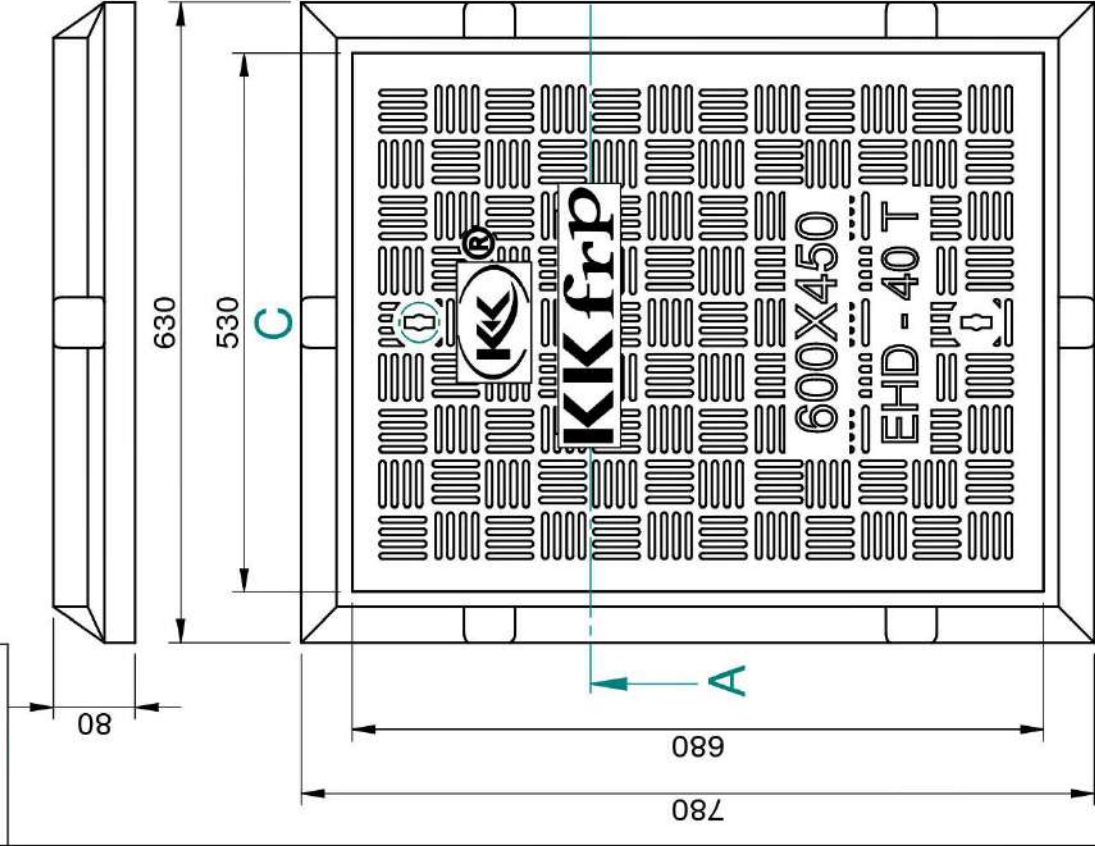

**DETAIL C  
KEY HOLE  
FOR LIFTING**

- ① CLEAR OPENING = 600 x 450 MM
- ② OUTER FRAME SIZE = 780 x 630 x 80 MM
- ③ OUTER COVER SIZE = 680 x 530 x 50 MM
- ④ APPROX WEIGHT = 53 KG

**NOTE:-**

- 1. ALL DIMENSIONS ARE IN MM.
- 2. DIMENSIONAL TOLERANCE +/- 1%

	Drawn	RJ	Checked	AB	Scale:	1:5	Projection:		
	DESCRIPTION:		MCEHD-09		Sheet No.		2 OF 2		
CONFIDENTIAL INFORMATION (UNAUTHORISED DISCLOSURE PROHIBITED)								DRG. NO.	MCEHD-09-450x600
								40 T	

**KK frp**