

Technical Specification/ Product Datasheet



KK-FRP AND KONCRETE PRODUCTS PVT LTD

1114 Hubtown Solaris
Prof N.S Phadke Road, Andheri (E)
Mumbai-400 069
INDIA
Ph: +91 22 66913250 ,
Mob: +91 9822036550 / 9850089903 ,
email: info@kkfrp.com / kkmgnsk@gmail.com
Web: www.kkfrp.com



Specific Product Code/s:	MCEHD13
Product Group:	KK-FRP FIBREGLASS COMPOSITE MANHOLE COVER & FRAME
Sub-Category:	Extra Heavy Duty EHD 40 T Cap. As per BSEN124:2015
Material Composition :	Unsaturated Polyester Resin UV Resistant ISO Grade, Emulsion Fibreglass Matt E Class, Accelerators, UV Resistant Pigment, Polymer Concrete in Quartz as Core,
Basic Dimensions (mm):	Clear Opening 900 x 450 mm Cover Size: 980 x 530 mm Cover Height: 50 mm Frame Size: 1080 x 630 mm Frame Height: 80 mm
Weight (kgs):	Approx. 82 kg
Load Rating Classification:	D400 (40T)
Features:	<ul style="list-style-type: none">➤ FRP Manhole Cover & Frame D400 as per BSEN124.➤ Heavy duty design to cope with the demands of heavily traffic in Main Roads , carriageways , Parkings etc.➤ Key Holes 2nos with (SS Key optional) & Lifting device provided .➤ Choice of Colour Available.➤ Anti skid surface.➤ Waterproof, Weatherproof, Burglar proof , Non corrossive, High Strenght to Wt ratio, Easy of handing as Light wt , Heat Resistant, Shockproof .➤ Provision for Logo of Buyer.➤ Additional Provision of Gasket (O-Ring) 6 mm Dia & SS Nut Bolts with Washer to make Water Tight (Optional) .

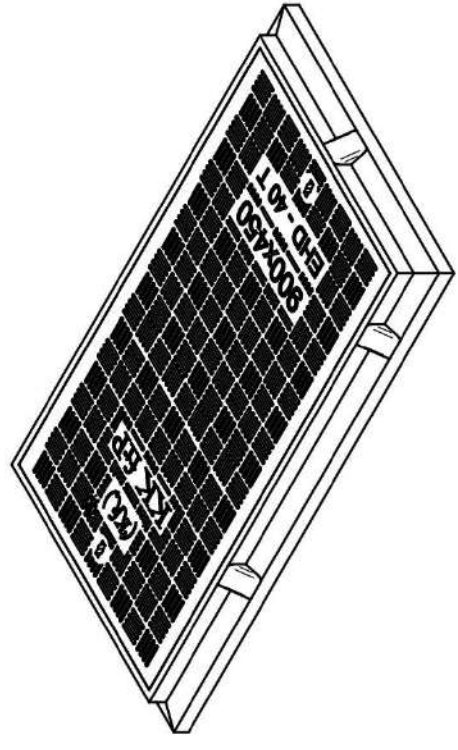
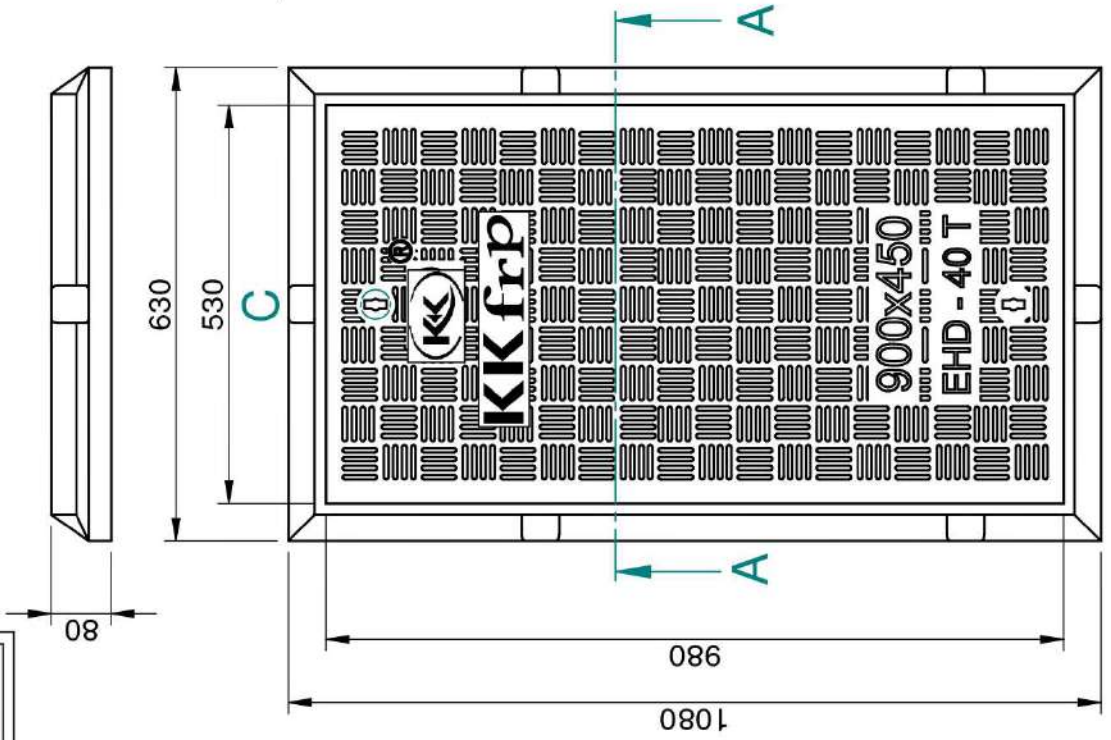
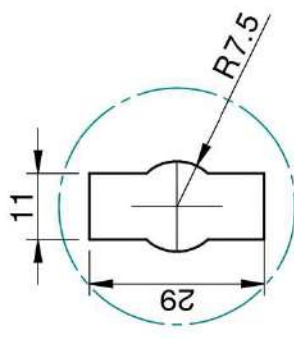
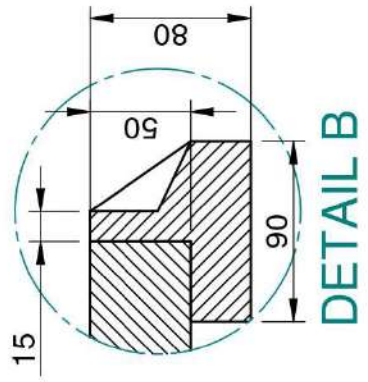
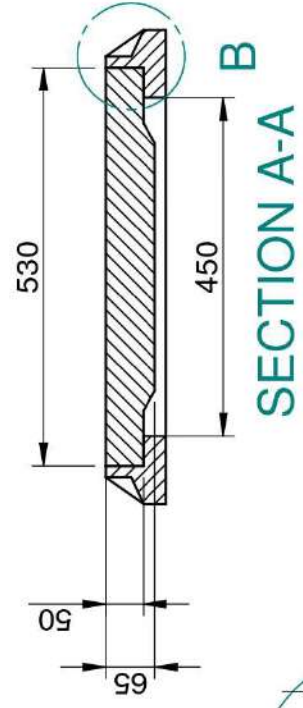

- ① CLEAR OPENING = 900 x 450 MM
- ② OUTER FRAME SIZE = 1080 x 630 x 80 MM
- ③ OUTER COVER SIZE = 980 x 530 x 50 MM
- ④ APPROX WEIGHT = 76 KG

	Drawn	RJ	Checked	AB	Scale:	1:5	Projection:	
	DESCRIPTION:				MCEHD-13	Sheet No.		2 of 2
CONFIDENTIAL INFORMATION (UNAUTHORISED DISCLOSURE PROHIBITED)				DRG. NO.		MCEHD-13-900x450 40 T		

KK frp

NOTE:-
 1. ALL DIMENSIONS ARE IN MM.
 2. DIMENSIONAL TOLERANCE +/- 1%